

Submersible Contractor Pumps

Versatile, really robust and definitely reliable



We move SOLIDS

MBH[®]
PUMPS

Handling Slurry is simple fo us



Agitator

Submersible Contractor Pump - CP Series, is a submersible high power, heavy duty slurry pump incorporating an agitator to suspend solids enabling the pump to handle high concentration slurries. Being Equipped with High-Chromium cast iron Wear parts, the pump delivers outstanding durability. The suction plate is adjustable enabling the pump to maintain the original performance.

CP Series Submersible Contractor Pumps

Technical Specifications :

Head : upto 50 meters
Capacity : upto 450 m³/hr
HP : upto 60
Solid Size : 40 mm
MOC : 27% high chrome impeller,
2% NI. CI volute
Frequency : 50 / 60 Hz

Applications

- Transferring & draining bentonite Slurry in piling.
- Draining cement slurry or sand carrying water in foundation works.
- Draining aggregated and ore wash water in mines and quarries.
- Collecting sediments in grit chambers at waste water treatment plants.
- Pumping scale at steel mills.
- Dewatering water containing drilling slurry during Jackwell / Intake well construction.
- Dewatering water containing grit and stone slurry.



Design

Motor protection

Sensors are well placed in the motor for Thermal Protection as well as moisture detection in the Motor. This ensures tripping of the motor in adverse condition.

Cable entry

Anti-wicking cable entry prevents water incursion due to capillary wicking should the power cable be damaged or the end submerged.

Mechanical seal with silicon carbide faces

Heavy duty dual mechanical seal arrangement is present in the oil chamber, which protects the motor from heavy slurry that needs to be pumped using Contractor series pumps.

High chrome cast iron impeller 27% and adjustable suction plate

Made of high-chromium with 27% chrome content ensures highest durability. Even if the performance drops due to wearing out of the impeller and suction plate, it can be improved by simply adjusting the suction plate.

Volute

Volute is made with 2% Nickel hardened cast iron ensuring long life of the pump.

Agitating mechanism

Agitator made of High-chrome material is shaft mounted and well placed at the bottom of the strainer. This agitator causes whirlpool effect breaking large particles and hence prevents any clogging of the pump.

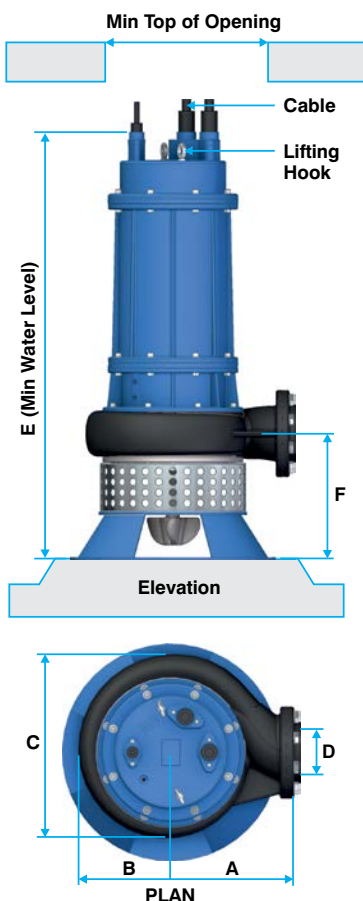

All Dimension are in mm

Model	Min. Opening	A	B	C	D	E	F	Weight in kg
4CPNSC5S4A	675	215	160	321	100	848	252	170
4CPNSC7.5S4A	675	215	160	321	100	948	252	187
4CPNSC10S4A	772	263	209	415	100	975	252	196
4CPNSC15S4A	772	263	209	415	100	1040	252	223
4CPNSC25S4A	798	280	218	440	100	1132	275	324
4CPNSC25S6B	889	330	259	515	150	1127	272	340
4CPNSC40S4A	890	335	255	533	100	1358	257	478
4CPNSC40S6B	950	362	288	575	150	1360	385	494
4CPNSC50S4A	890	335	255	533	100	1408	357	491
4CPNSC50S6A	950	362	288	575	150	1410	385	516
4CPNSC60S4A	890	335	255	533	100	1458	357	538
4CPNSC60S6A	950	362	288	575	150	1460	385	546

Performance curves for 50 Hz / 60 Hz

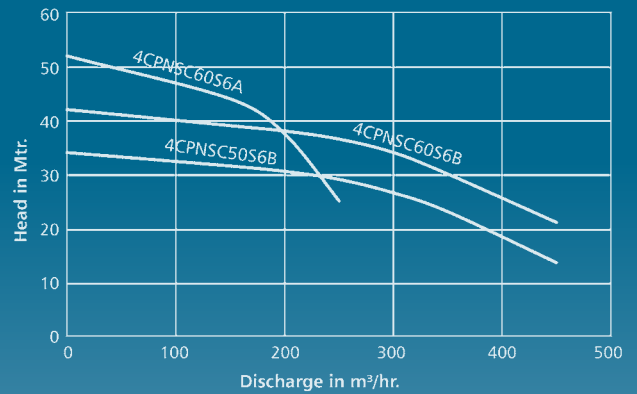
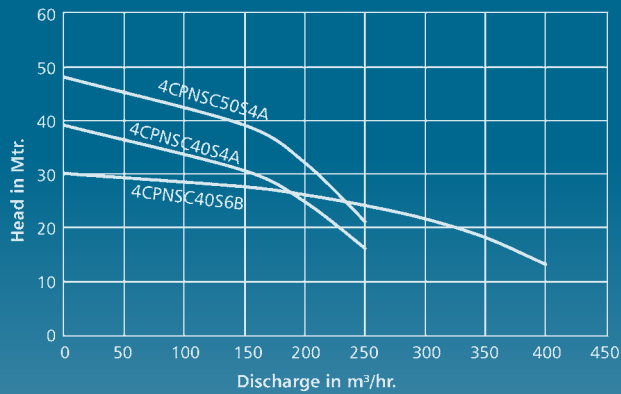
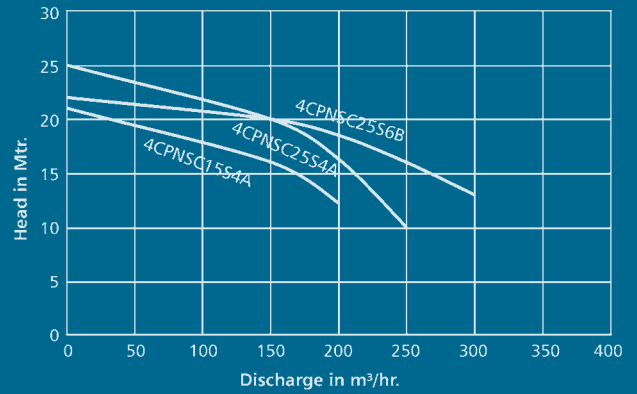
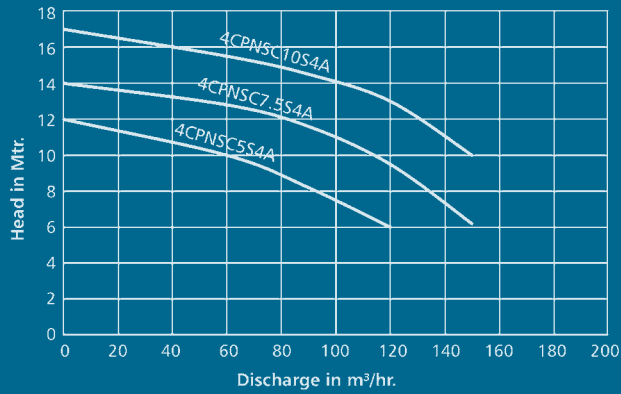

Inquire about our other product range for Dewatering Pumps



DCAL Series
Dewatering Pumps



DS Series Duplex Steel
Submersible Pumps



Submersible
Portable Pumps



Pro-Prime Series
Autoprime Pumps

Specifications and performance are subject to change without prior notice. Images used are for illustration purpose only.



mbh pumps (gujarat) pvt. ltd.
Plot No. 14, G.I.D.C. Indl. Estate,
Naroda, Ahmedabad - 382 330, India.
+91-79-2282 3066, 2282 1018
marketing@mbhpumps.com
exports@mbhpumps.com
www.mbhumps.com

