



**OPERATION &  
MAINTENANCE MANUAL**

**SUBMERSIBLE SEWAGE PUMP**



**MBH<sup>®</sup>  
PUMPS**

*A Mark of Quality*

## CROSS SECTION DRAWING

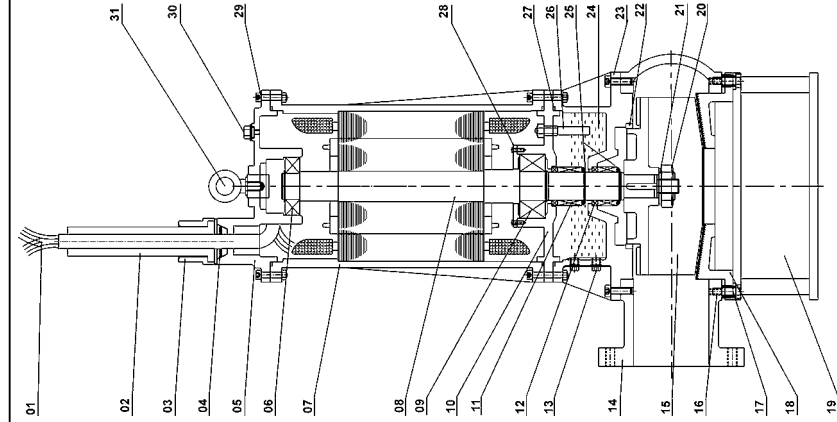

No.	DESCRIPTION	MATERIAL
01	CABLE	PVC. INSU. SHEATHED
02	CABLE PROTECTOR	NITRILE RUBBER
03	GLAND COVER	C.I. IS-210, FG260
04	CABLE GROMMET	NITRILE RUBBER
05	TOP COVER	C.I. IS-210, FG260
06	BALL BEARING (N. D.E.)	STD. MAKE
07	STATOR	C.I. IS-210, FG260
08	ROTOR SHAFT	S.S.410
09	BALL BEARING (D.E.)	STD. MAKE
10	BEARING COVER	C.I. IS-210, FG260
11	MECH. SEAL (UPPER)	C / Cr. Steel
12	MECH. SEAL (LOWER)	Si.C./Si.C.
13	OIL PLUG	S.S.304
14	VOLUTE	C.I. IS-210, FG260
15	IMPELLER	C.I. IS-210, FG260
16	HEX BOLT	S.S.304
17	ADJUSTING SCREW	S.S.304
18	SPIRAL PLATE (WEAR PLATE)	C.I. IS-210, FG260
19	PUMP STAND	M.S.
20	IMPELLER LOCK NUT	S.S.304
21	IMPELLER LOCK NUT WASHER	S.S.304
22	NECK RING	GUN METAL
23	OIL CHAMBER	C.I. IS-210, FG260
24	OIL	HYLUBE. MILCY-G-40
25	EXTERNAL CIRCLIP	SPRING STEEL
26	ELECTRODE	ALUMINIUM
27	'O' RING	NITRILE RUBBER
28	BBC	C.I. IS-210, FG260
29	ALLEN BOLTS	S.S.304
30	PLUG	S.S.304
31	EYE BOLTS	S.S.304

## CONSTRUCTION OF SEWERAGE SUBMERSIBLE PUMPSET

'MBH' Non-Clog submersible sewage pumps are of close couple compact design and have pump below and motor above construction hence sump cleaning is possible to the minimum level. These are powered by squirrel cage induction dry motors suitable for operation at 400/440 volts, 3 phase, 50 Hz, A.C. Supply; bearing of these pumps are grease packed. Being a Submersible pump, it saves a lot of cost of construction compared to other conventional pumps and also provides noise free operation. Pumps are fitted with high efficiency non-clog or free flow impeller for smooth and economical pumping operation. Since they work under pumping liquid, suction is always flooded, hence no need of priming or suction pipe. Pumps are fitted with double mechanical seals to separate motor chamber from oil chamber and oil chamber from liquid being pumped. Pumps are provided with special safety devices like moisture detection sensor and thermister protection against high winding temperature. That can also be provided with special lowering arrangement for easy access of the pump for maintenance.

## RECOMMENDATIONS

1. Follow maintenance schedule strictly, so as to avoid costly repairs in the long run.
2. 'MBH' non-clog submersible pumpsets are being supplied with special features like over heating protection (Thermister) and seal monitor sensor, control panel is a mandatory supply with each and every pumpset. Ensure that pumpset is connected properly to the control panel.
3. Pump can be installed permanently with automatic coupling device fixed at the bottom of sump or portable installation with the help of flexible hose pipe and pump is suppose to pumpout suspended solids. However if it is thrown into the sump and digs into very heavy sludge it may result into the reduction in capacity.
4. If pumping media available is falling short of the pump capacity, it will result in spurt, which is harmful for the pump. In such a case reduce discharge by throttling.
5. Ensure that pump rotates in correct direction (clockwise). Counter clockwise rotation result in lower discharge and increased wear. At instant of starting sewage pump should give anticlockwise jerk.

The rotation of impeller should match the arrow on the pump casing.

In case of reverse rotation the current consumption will rise and pumpset will produce unwanted noise.

6. Avoid too many creases in the hosepipe (in case of portable installation), it results in increased friction losses. Use the shortest possible delivery line.
7. Protect cable from damage-during storage, transportation and operation. A damaged cable may give shock or burn the motor.
8. Always earth the unit, before starting.
9. Never hoist the pumpset up or down by the connecting cable.
10. Use NRV if pipe length is more than 4.5 mtrs.

## CABLE CONNECTION OF MOTOR TO CONTROL PANEL

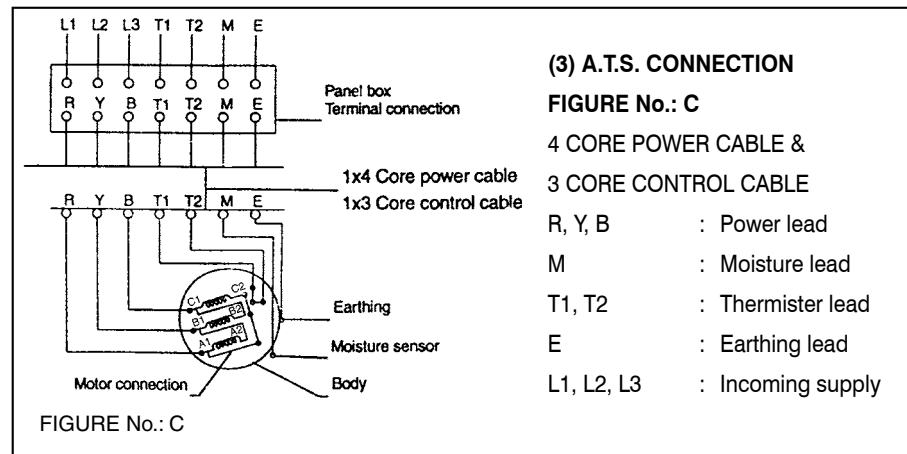
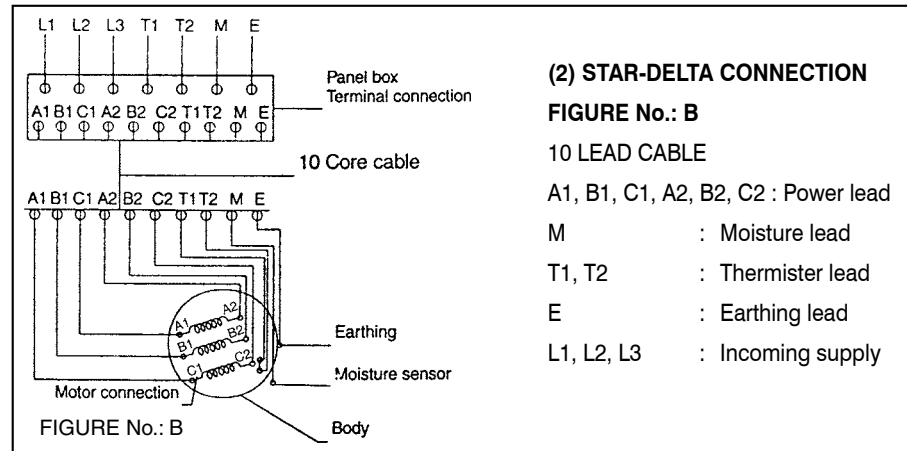
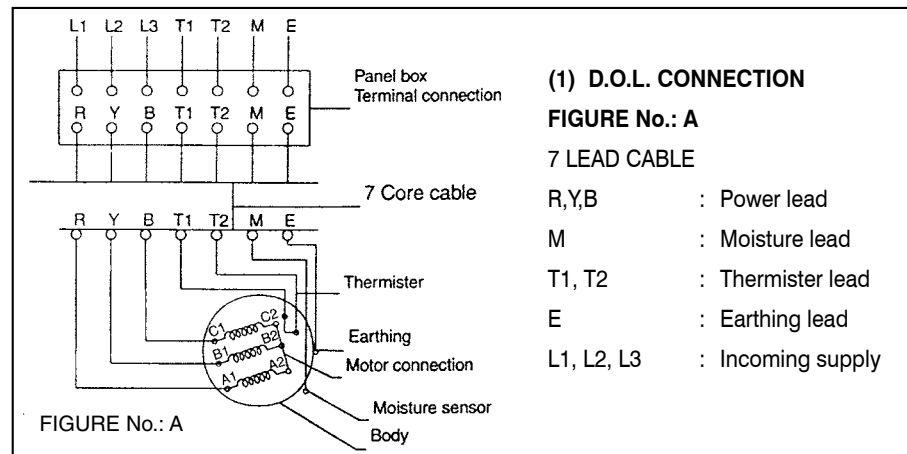

## PORTABLE MOUNTING

The pump must be installed in vertical motor position above on a solid floor.

For portable mounting, stand is supplied along with the pumpset.

Suspend the pump from the chain and shackle attached to the eyebolt which is on the top cover.

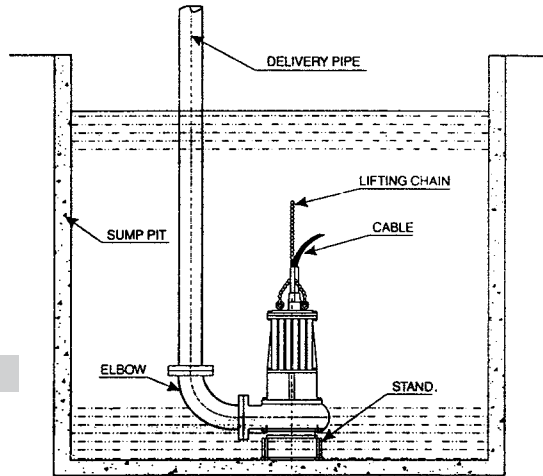

## PERMANENT MOUNTING

There are four major parts of auto coupling device:

1. Base Plate
2. Guide Piece
3. Guide Pipe Holder
4. Bracket

- With the help of foundation bolt & concrete, install the Base plate in the sump. For vibration and trouble free operation, it is necessary that foundation bolts should be tight. Fix the guide piece on the base plate.
- Put the guide pipe on the base plate & fix up the guide pipe holder at upper portion of the sump. Fix the guide pipe holder in such a way that there should not be vertical play in guide pipe and guide pipe should be parallel to discharge pipe.
- Length of the guide pipe required is more than 6 mtrs. Lengthen the guide pipe by adding more guide pipe and using guide pipe coupling and connection pins.
- The connection of the discharge pipe & the base plate is done by means of an elbow & gasket.
- Bracket is fixed to the pump flange with alien screws. The alien screws should be tightened equally crosswise to prevent leakage from the sealing. Place the gasket in bracket.
- Fasten chain to eyebolt on pump top by means of shackle.
- Let pump with bracket glide over guide pipe holder and lowered down in to sump by way of guide pipe.
- The slot of the bracket must fit into the guide piece of base plate and the claus of the bracket must grip to the calms at the sides of the base plate. By that the pump automatically gets into correct position and by its own weight seals the discharge connection at the bottom. A release of air bubble may be noted as the connection is made. Finally hang chain on the special hook on the guide pipe holder.

## FOR INSTALLATION AND EASY SERVICING

The 'MBH' automatic coupling device with its single guide rail allows loose installation and easy removal for inspection and servicing without the need for maintenance personnel to enter the sump. A special base plate is fixed to the sump floor and the delivery pipe is connected to the base plate. A 50 mm diameter guide rail connects the top of the sump. The pump is lowered on the guide rail and settles easily on the base plate to which it is automatically locked by virtue of its own weight. Removal is the reverse of this and the seal between the pump and the base plate is automatically broken as the pump is lifted. Inspection and removal for maintenance purpose can therefore be carried out easily carried outside the sump with minimum inconvenience.

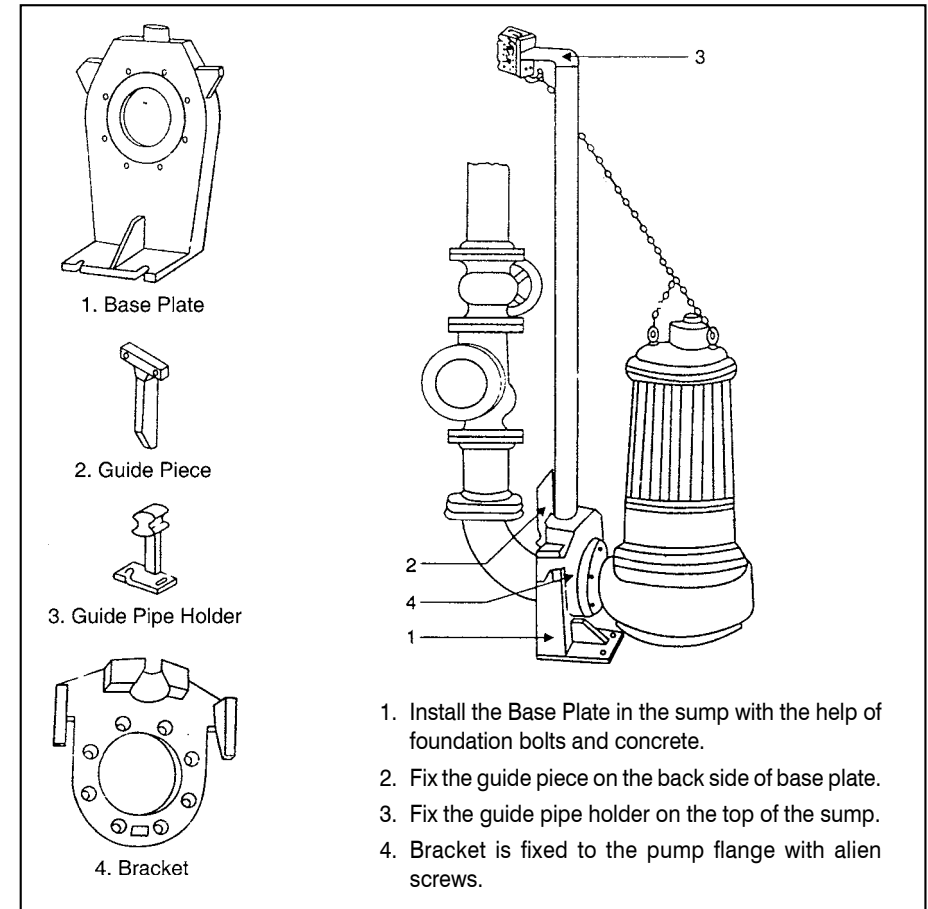

1. Install the Base Plate in the sump with the help of foundation bolts and concrete.
2. Fix the guide piece on the back side of base plate.
3. Fix the guide pipe holder on the top of the sump.
4. Bracket is fixed to the pump flange with alien screws.

## PRECAUTION FOR LONG STORAGE

Clean the pump set with fresh water and wipe the cable. Put pump set in cool, dry place in vertical position and the cable wrapped on top of the pump.

Do not leave cable on the floor where it is likely to get damaged.

## WARNING

- Ensure that pump set rotates in the correct direction of rotation.
- Always operate pumpset with the original control panel supplied by the manufacturer.
- Never bypass any protection like Thermister, Moisture sensor & Level controller.  
In case the pump set stops due to above protection, remove the pump set from sump and correct the defect.
- Protect the cable from damage.
- Ensure proper earthing of the pump set before starting.

## MAINTENANCE

Practically 'MBH' non-clog submersible pumpset is totally maintenance free. However oil in seal chamber has to be checked every six months and needs to be replaced if quality gets deteriorated or it is to be changed after one year or 5000 working hrs. whichever is early. List of standard oil types is as under.

- ◆ BPCL - Hydrol46/Turbo 46 ◆ HPCL - Hylube-30/Milcy-40 ◆ IOC - Servo super 10

## PROCEDURE OF OIL CHANGE

Position the pump horizontally as shown in Fig.

Place a suitable receptacle under the threaded plug. Remove the plugs with 'O' ring and drain the oil. If the oil is between light yellow and white in colour this means the seal is intact and the oil change can proceed. However, if there is more water than oil in the chamber you must inspect the mechanical seals and fit new ones if necessary. Screw the threaded plugs, with 'O' ring back in.

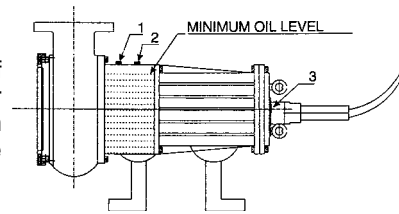

## INSTALLATION LAYOUT

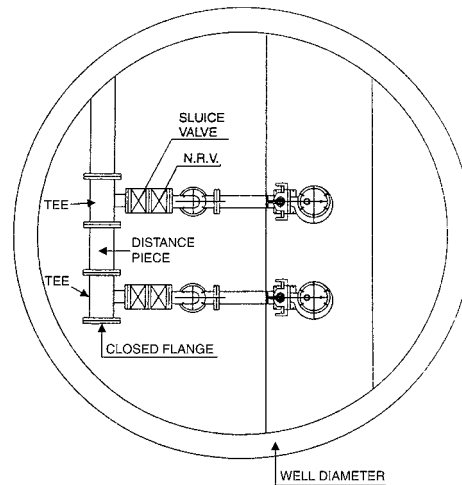
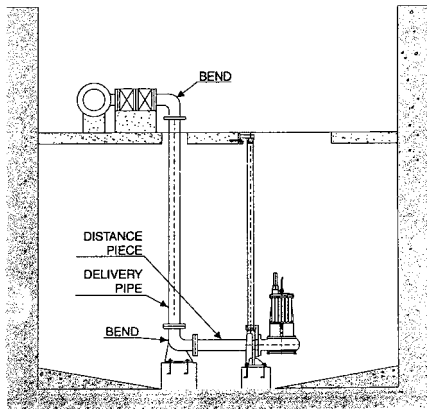

## TROUBLE SHOOTING CHART

						 <b>SUBMERSIBLE SEWAGE PUMP</b>	
Pump fails to deliver	The discharge is too low.	The line current is excessive.	The total head is too low.	The power consumption is excessive.	Noisy operation of pump.	CAUSE	REMEDY
	•					The pump delivers against an excessively high discharge pressure.	Open the isolating valve further, until the duty point conditions have been attained.
	•					The pump and / or piping are incompletely vented.	Vent the pump & system completely.
	•		•			Suction line or impeller clogged.	Remove deposits in the pump & piping.
	•	•	•	•		Reverse rotation.	Change over two of the phase leads of the power supply cable.
	•	•	•	•		Excessive wear of the pump internals.	Replace worn components by new one.
		•				Operating Voltage too low.	Check the supply terminals inform the supply authorities.
		•	•			The motor is running on two phase only.	Replace the defective fuse, check the cable connection.
				•		The rotor is out of balance.	Clean the rotor, Rebalance the rotor dynamically.
•						The motor refuses to run because there is no voltage.	Check the electrical system, inform the supply authority.
•						The pump is silted up.	Clean out the inlet, Pump components & check valve.
•	•					Defective motor or cable.	Please consult our works.
•	•	•				Defective riser pipe. (pipe & gasket)	Replace defective lengths of riser pipe by new ones, fit new gasket.
•						Abnormal (excessive) drop in the liquid level during operation.	Please consult our works.
	•	•	•			The Star-Delta motor remains stuck at the star stage during start-up.	Check the switchgear/control panel.
	•					The isolating valve in the discharge line is not fully open.	Open the valve fully.
	•	•			•	Excessive amount of air or gas in the liquid pumped.	Check the operating parameters with reference to duty point. & correctness of submergence.
		•				Defective Ammeter.	Replace with new one.
		•				The insulation resistance of the winding is inadequate (The minimum resistance in warm condition during operation should be 1000 ohms/volt of operating volt.)	Please consult our works.
		•	•	•		Defective radial bearing in the motor.	Please consult our works.
				•		Vibration caused by improper installation.	Correct the installation.
•						The temp. sensor for monitoring the temp. of winding in the control circuit has stopped the motor because the winding temp is too high.	Wait for some time so that the motor cools down & the pumpset will start automatically.

# MBH PUMPS

# GUARANTEE

## SUBMERSIBLE SEWAGE PUMP

The pump is guaranteed against defects in material and workmanship under normal use and service for the period of 15 months from the date of purchase or 12 months from the date of commissioning, whichever is less.

The General terms and conditions for above guarantee are :

1. This guarantee is valid only if the pump is operated strictly as per the Instructions given in the user guide attached herewith.
2. Our obligation shall be limited to rectifying; repairing or replacing defective items, ex-works/service station/Authorized Service Center, provided the purchaser has given immediate written notice. The equipment for repairs should be returned to us duly packed, on pre-paid freight basis.

Model : \_\_\_\_\_ Pump Sr. No. \_\_\_\_\_

Customer Name : \_\_\_\_\_

Address : \_\_\_\_\_

Date of Purchase / Bill No.: \_\_\_\_\_

Dealers Name : \_\_\_\_\_

Signature : \_\_\_\_\_ Date : \_\_\_\_\_

---

**mbh pumps (gujarat) pvt. ltd.**

Plot No. 14, G.I.D.C. Naroda Industrial Estate, Ahmedabad - 382 330, India.  
Phone : 079-2282 3066, 2282 1018 • Fax : 079-2282 1511  
E-mail : mbhpumpsad1@sancharnet.in • Website : www.mbhpumps.com

# Our Product Range



**PORTABLE  
SUBMERSIBLE  
PUMP**



**HORIZONTAL  
SPLIT CASING  
PUMP**



**POLDER /  
DEWATERING  
PUMP**



**CENTRIFUGAL  
PUMP  
TYPE HC**



**SELF PRIMING  
CENTRIFUGAL  
PUMP**



**ISO 9001:2008**  
*Certified Company*

**MBH<sup>®</sup>**  
**PUMPS**

**mbh pumps (gujarat) pvt. ltd.**

14, G.I.D.C. Naroda Indl. Estate, Ahmedabad-382 330, India.  
Phone : 079-2282 3066 / 2282 1018  
Fax : 079-2282 1511  
E-mail : [marketing@mbhpumps.com](mailto:marketing@mbhpumps.com)  
Website : [www.mbhpumps.com](http://www.mbhpumps.com)

*A Mark of Quality*